

# Contents

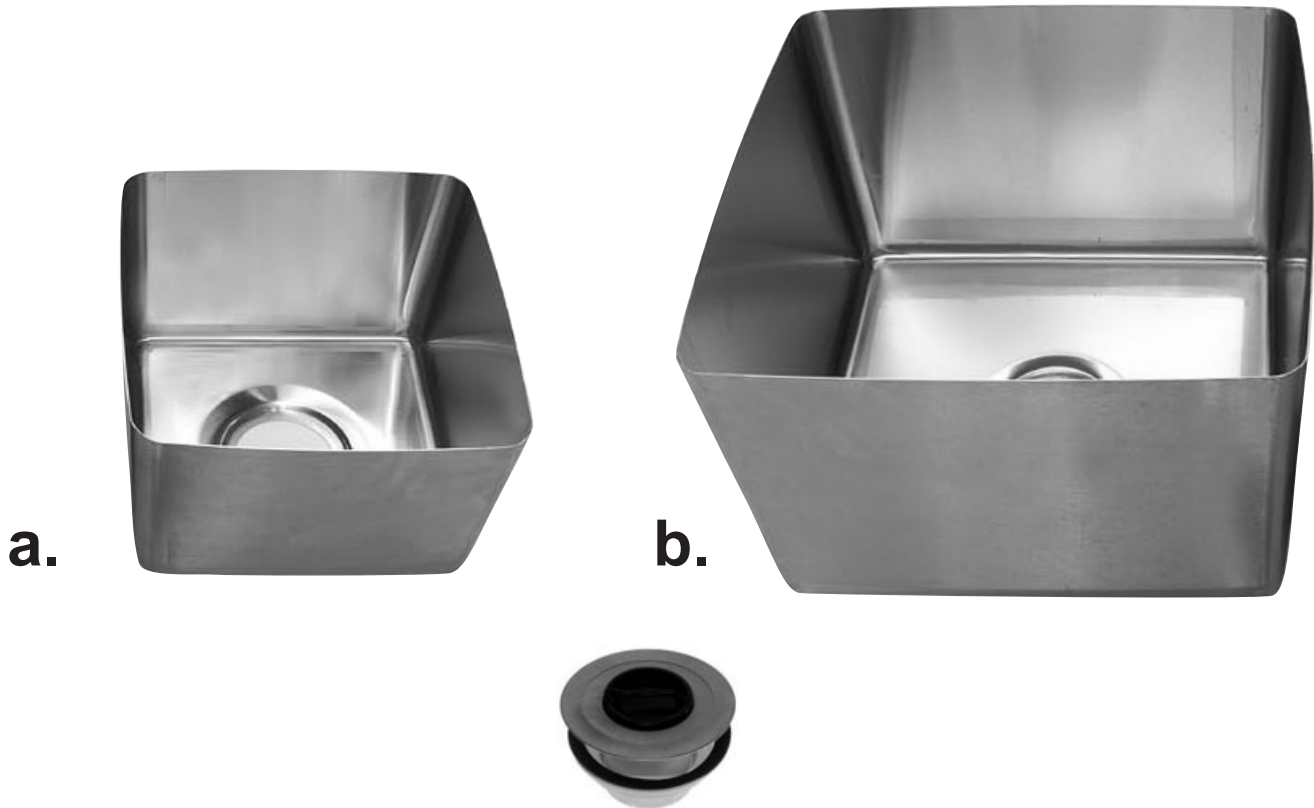

CRH Series Fabricated Bowls	C1
Hand Basins	C3
Pressed Bowls	C4
CRH Series Knee Operated Sinks	C5
Mop Sinks	C7
In Sink Dry Basket Arrestors	C8
In-Floor Dry Basket Arrestors	C10
Wastes	C11
Overflow Tubes and Drains	C12

20MOP	C7	RB3	C6
20MOP-9	C7	SBF303020PW	C1
40STD	C11	SBF353020PW	C1
50BWA	C11	SBF353030PW	C1
50PGR	C11	SBF403020PW	C1
72-FS	C11	SBF403520PW	C1
72-RK	C11	SBF404030PW	C1
37333	C12	SBF453030PW	C1
93003	C10	SBF454030PW	C1
93003T	C10	SBF454525PW	C1
93012	C10	SBF454530PW	C1
93013	C10	SBF604530PW	C1
93026	C8	WABR	C6
93027	C9	WB2	C3
93028	C9	WB3	C3
93030	C9	WB5	C3
93031	C8	WB6/BKT	C3
93032	C8	WB6/GI	C3
93033	C9	WD20T	C11
93033	C10		
93034	C9		
93035	C8		
93035	C9		
93036	C8		
93037	C9		
93039	C8		
93039	C9		
93040	C10		
93040T	C10		
1409111	C9		
ASKOB1	C5		
ASKOB2	C5		
B1	C4		
B2	C4		
B3	C4		
B4	C4		
B5	C4		
B6	C4		
B7	C4		
B8	C4		
B10	C4		
B11	C4		
BABR	C6		
E13-0242	C12		
E16-4011A	C12		
E16-4031A	C12		
E18-1822	C12		
ICE403530	cii		
JUVEC	C4		
K0460-2290	C12		
MOPSINK	C7		
PW89/50	C11		
RB1	C6		
RB2	C6		



ITEM	STOCK CODE	SIZE (W x L x D)	FEATURES
a.	<b>SBF303020PW</b>	300mm x 300mm x 200mm Centre punched	<ul style="list-style-type: none"> <li>• Constructed from 1.2mm 304 grade stainless steel</li> <li>• Polished finish no. 4</li> <li>• <b>Suitable for fitting Dry Basket Arrestors®</b></li> <li>• Supplied with 89/50mm standard waste and plug (Stock Code PW89/50)</li> <li>• Punched with 89mm waste hole</li> <li>• Larger 125mm hole to suit SinkSafe®Large and SinkShield®Large can be punched on request</li> </ul> <p>Custom sizes available on request</p>
	<b>SBF353020PW</b>	350mm x 300mm x 200mm Centre punched	
	<b>SBF353030PW</b>	350mm x 300mm x 300mm Centre punched	
	<b>SBF403020PW</b>	400mm x 300mm x 200mm Centre punched	
	<b>SBF403520PW</b>	400mm x 350mm x 200mm Centre punched	
	<b>SBF453030PW</b>	450mm x 300mm x 300mm Centre punched	
	<b>SBF454030PW</b>	450mm x 400mm x 300mm Centre punched	
b.	<b>SBF404030PW</b>	400mm x 400mm x 300mm Centre punched	
	<b>SBF454525PW</b>	450mm x 450mm x 250mm Offset punched	
	<b>SBF454530PW</b>	450mm x 450mm x 300mm Offset punched	
	<b>SBF604530PW</b>	600mm x 450mm x 300mm Offset punched	

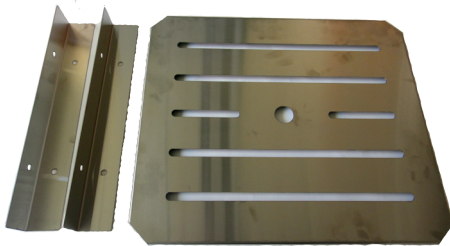
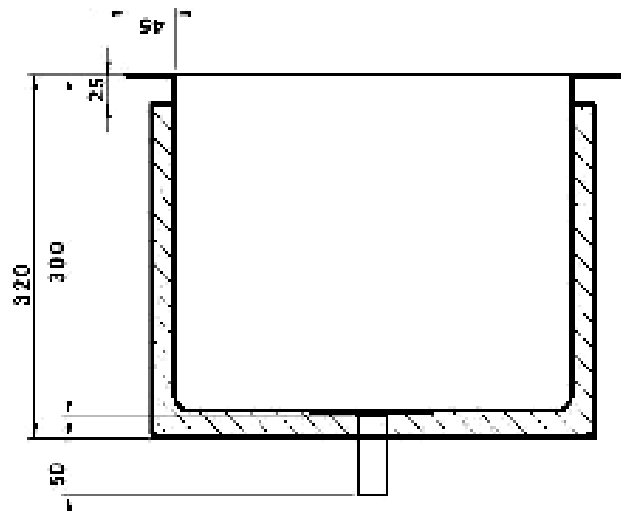
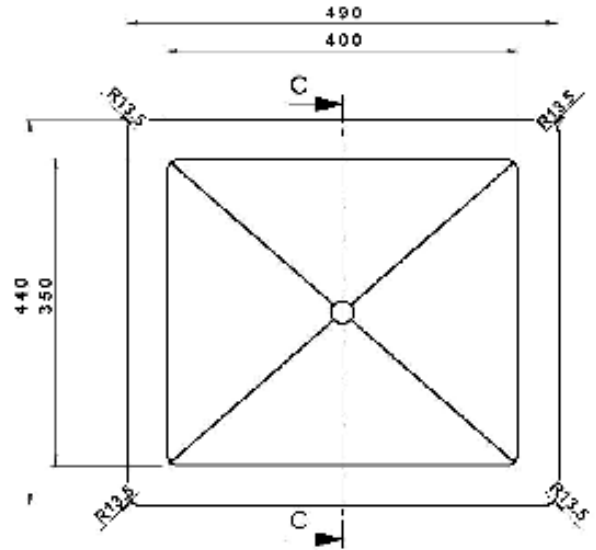

ITEM	STOCK CODE	SIZE (W x L x D)	FEATURES
a.	ICE403530	400mm x 350mm x 300mm Centre punched	<ul style="list-style-type: none"> <li>• 304 Grade Stainless Steel Inner Bowl, Outer Skin and Fixing Brackets</li> <li>• Polyurethane Foam Insulation between the Outer Skin and the Inner Bowl.</li> <li>• Designed so it may be either welded or dropped into the bench top</li> <li>• 2 x side brackets are provided to give stronger installed strength.</li> <li>• Removable bottom slotted ice tray &amp; 25mm Drain hole so excess water drains away to preserve ice.</li> </ul>

Hand Basins

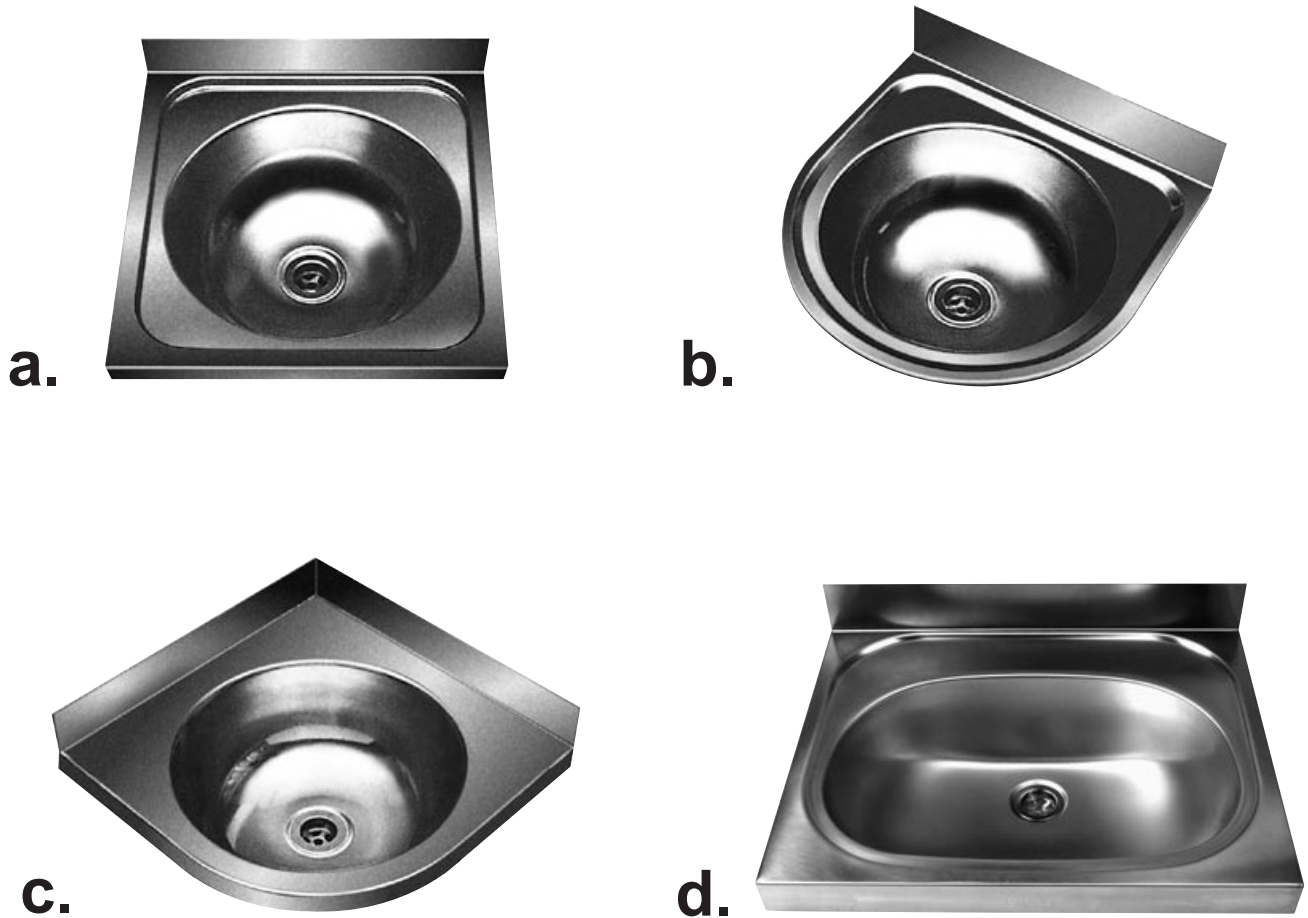

ITEM	STOCK CODE	DESCRIPTION	OUTSIDE DIMENSIONS (mm) W x L x D	FEATURES
a.	<b>WB2</b>	Square basin with round bowl	360 x 360 x 110	<ul style="list-style-type: none"> <li>• Material thickness 0.9mm</li> <li>• Constructed from 304 grade stainless steel</li> <li>• Polished finish</li> <li>• 50mm drain hole</li> </ul>
b.	<b>WB3</b>	Round basin with round bowl and rear upstand	360 x 355 x 110	
c.	<b>WB5</b>	Square corner basin with round bowl, round front and upstand on two sides	350 x 350 x 110	
d.	<b>WB6/GI</b>	Rectangular basin with rectangular bowl and rear upstand <b>NO bracket</b>	520 x 400 x 145	
	<b>WB6/BKT</b>	Rectangular basin with rectangular bowl and rear upstand <b>Including bracket</b>	520 x 400 x 145	

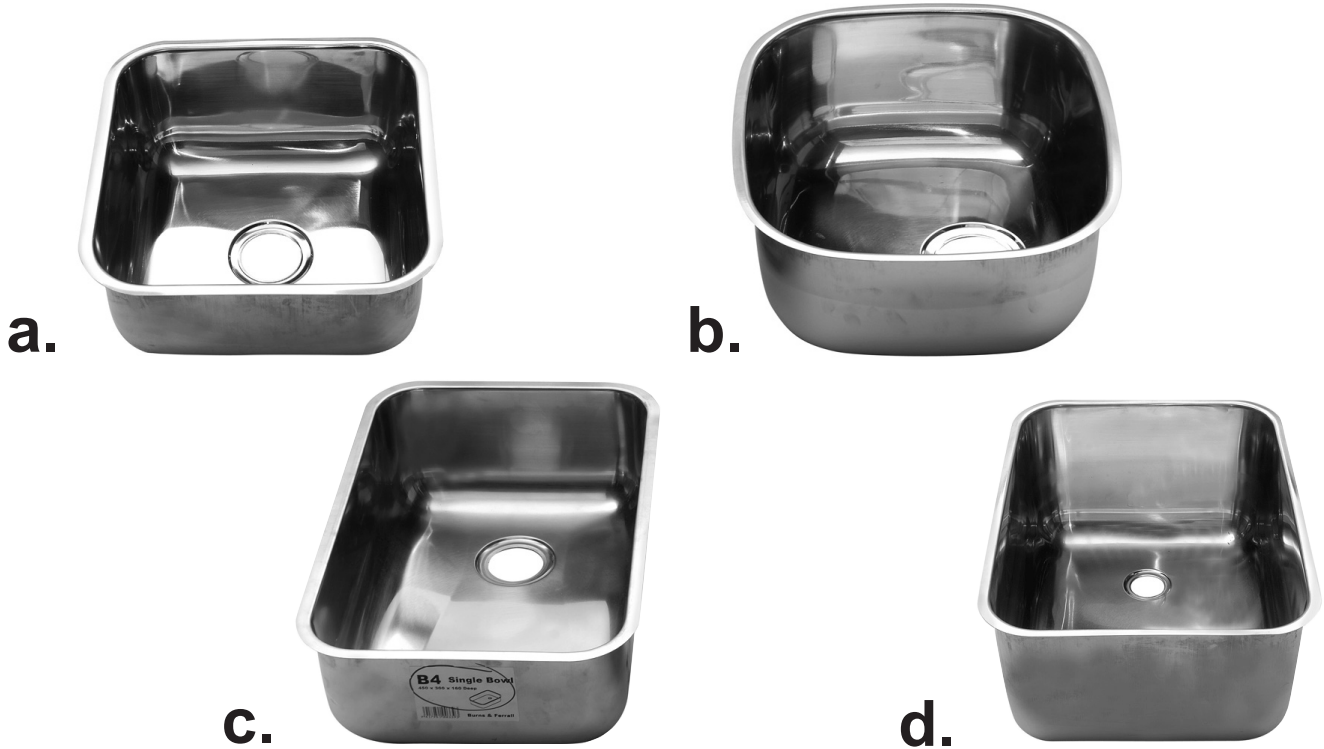

ITEM	STOCK CODE	SIZE (W x L x D)	FEATURES
a.	B1	350mm x 300mm x 150mm	<ul style="list-style-type: none"> <li>• Material thickness 0.9mm</li> <li>• Constructed from 304 grade stainless steel</li> <li>• 15mm polished flange</li> <li>• 50mm drain hole</li> </ul>
b.	B2	306mm x 306mm x 160mm	
	B3	406mm x 360mm x 180mm	
c.	B4	460mm x 306mm x 160mm	
	B5	508mm x 358mm x 180mm	
	B6	558mm x 360mm x 189mm	
	B8	356mm x 253mm x 125mm	
	B10	282mm x 225mm x 121mm	
	B11	512mm x 409mm x 235mm	
	JUVEC	400mm x 330mm x 160mm	
d.	B7	610mm x 463mm x 300mm	

CRH Series Knee Operated Sinks



a.

ITEM	STOCK CODE	DESCRIPTION	FEATURES
a.	ASKOB1	Knee operated sink <b>without</b> temping valve	<ul style="list-style-type: none"> <li>• Hands free, knee operation</li> <li>• Large front panel 420mm x 150mm</li> <li>• Automatic water shutoff</li> <li>• Outside dimensions 521mm x 408mm x 200mm deep</li> <li>• Constructed from 304 stainless steel</li> <li>• Body and shroud material thickness 1.2mm</li> <li>• Sink material thickness 0.9mm</li> <li>• Polished finish</li> <li>• 40mm drain</li> <li>• Countersunk screws gives flush finish to side of unit</li> <li>• 5 Star WELS rating and AS/NZS 6400:2005 compliant</li> <li>• Waterflow 6 litres per minute</li> <li>• Available with or without temping valve to regulate water temperature</li> <li>• Automatic water shut-off after 7 seconds</li> </ul>
	ASKOB2	Knee operated sink <b>including</b> temping valve	



ITEM	STOCK CODE	DESCRIPTION	INSIDE DIMENSIONS	FEATURES
<b>a.</b>	<b>RB1</b>	Round bowl with 25mm flange	280mm Diameter 115mm Deep	<ul style="list-style-type: none"> <li>Material thickness 0.9mm</li> <li>Constructed from 304 grade stainless steel</li> <li>Polished finish</li> <li>40mm drain hole</li> </ul>
	<b>RB2</b>	Round bowl with 25mm flange	330mm Diameter 115mm Deep	
	<b>RB3</b>	Round bowl with 25mm flange	310mm Diameter 150mm Deep	
<b>b.</b>	<b>BABR</b>	Basin bracket to suit WB6		
<b>c.</b>	<b>WABR</b>	Waste bracket to suit WB2, WB3, WB5, RB1 and RB2		



ITEM	STOCK CODE	DESCRIPTION	DIMENSIONS (MM) (W x L x D)	FEATURES
a.	<b>MOPSINK</b>	Pressed bowl with large flange	520 x 420 x 240	<ul style="list-style-type: none"> <li>Constructed from 304 grade stainless steel</li> <li>Material thickness 1.2mm</li> <li>50mm polished flange</li> <li>50mm drain in centre</li> </ul>
b.	<b>20MOP</b>	Cleaner's sink with grid and brackets	560 x 460 x 255	<ul style="list-style-type: none"> <li>Constructed from 304 grade stainless steel</li> <li>Material thickness 1.2mm</li> <li>25mm polished flange</li> <li>25mm splashback</li> <li>50mm drain in centre</li> </ul>
	<b>20MOP-9</b>	Cleaner's sink with grid and brackets	558 x 450 x 235	<ul style="list-style-type: none"> <li>Constructed from 304 grade stainless steel</li> <li>Material thickness 0.9mm</li> <li>25mm polished flange</li> <li>25mm splashback</li> <li>50mm drain in centre</li> </ul>



**IN SINK DRAIN PROTECTOR - FEATURES**

**In-Sink screening devices for the effective removal of solids from wastewater**

The Eco Guardian's Drain Protector range are the most effective products available for the removal of solid waste from waste water in sinks. These products are intended for use in commercial kitchens to screen out and retain solid waste from the waste water.

**a**

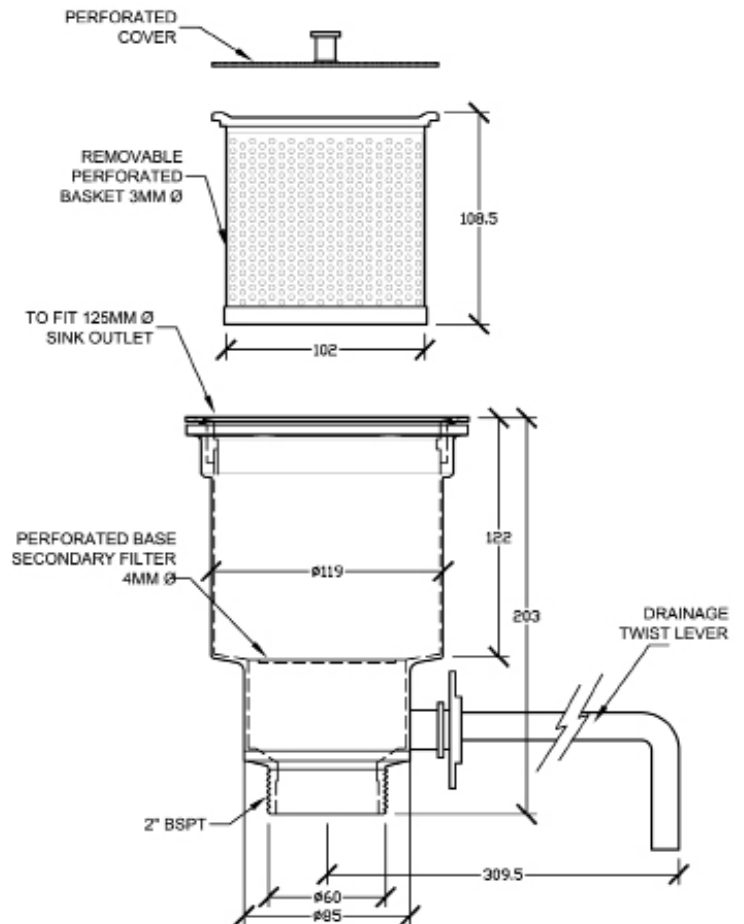

ITEM	STOCK CODE	DESCRIPTION	FEATURES
a.	SL850	125mm diameter in-sink Drain Protector with ball valve	<ul style="list-style-type: none"> <li>Fits a 125mm sink outlet</li> <li>Kitchen staff friendly &amp; easy to use</li> <li>Eliminates the need for other sink screening products</li> <li>Large Stainless Steel basket</li> <li>Easy to lift out &amp; return</li> <li>Solid, durable &amp; dependable</li> <li>Watermarked and WSAA appraised</li> <li>Connects to a standard 50mm water trap</li> </ul>



**IN SINK DRAIN PROTECTOR - FEATURES**

**In-Sink screening devices for the effective removal of solids from wastewater**

The Eco Guardian's Drain Protector range are the most effective products available for the removal of solid waste from waste water in sinks. These products are intended for use in commercial kitchens to screen out and retain solid waste from the waste water.

**a**

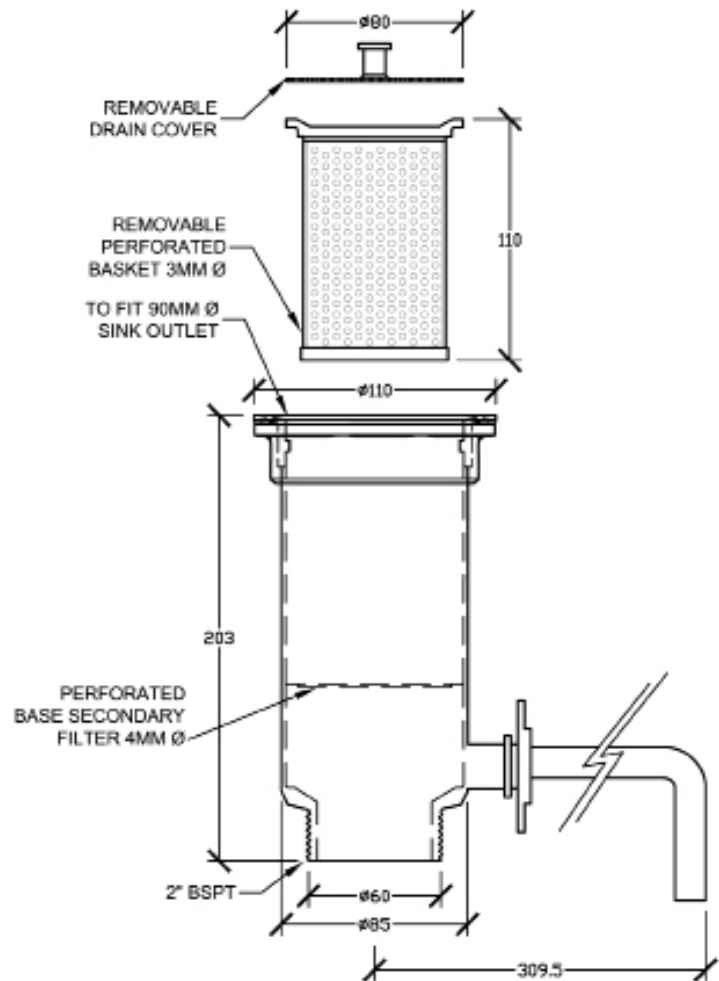

ITEM	STOCK CODE	DESCRIPTION	FEATURES
a.	SL340	90mm diameter in-sink Drain Protector with ball valve	<ul style="list-style-type: none"> <li>• Fits a 90mm sink outlet</li> <li>• Kitchen staff friendly &amp; easy to use</li> <li>• Eliminates the need for other sink screening products</li> <li>• Large Stainless Steel basket</li> <li>• Easy to lift out &amp; return</li> <li>• Solid, durable &amp; dependable</li> <li>• Watermarked and WSAA appraised</li> <li>• Connects to a standard 50mm water trap</li> </ul>



In Sink screening devices for the effective removal of solids from wastewater

a.

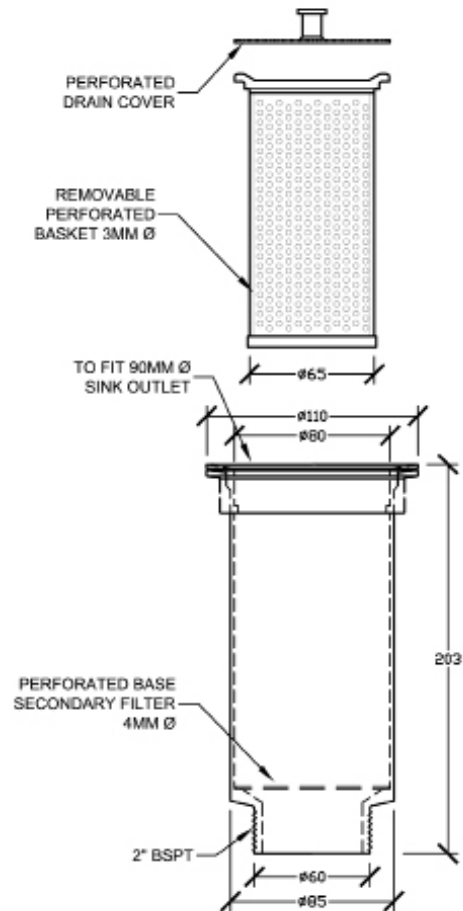

ITEM	STOCK CODE	DESCRIPTION
a.	S450	90mm diameter in-sink Drain Protector. Stainless steel with stainless steel face, plug and filter.



In Sink screening devices for the effective removal of solids from wastewater

a.

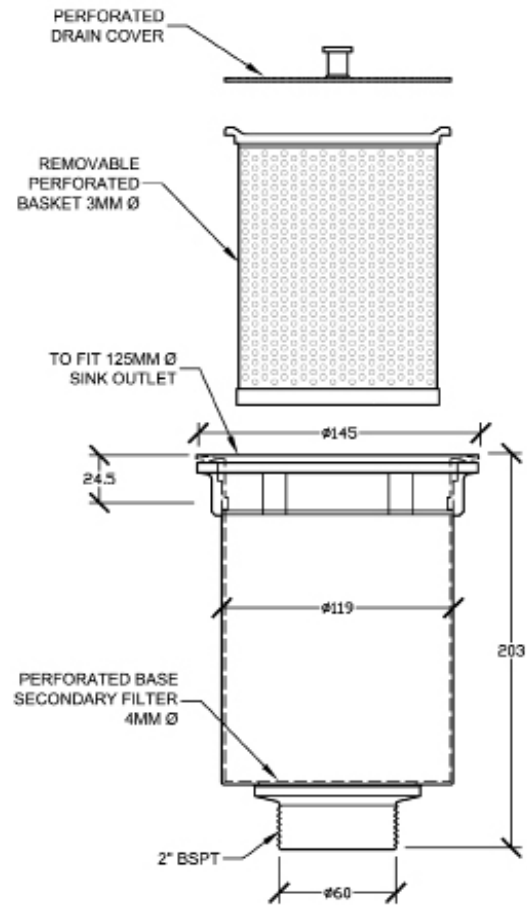

ITEM	STOCK CODE	DESCRIPTION
a.	S1100	125mm diameter in-sink Drain Protector. Stainless steel with stainless steel face, plug and filter.
ITEM	STOCK CODE	DESCRIPTION
	BS340	Spare basket for SL340 & S450 units.
	BS850	Spare basket SL850 & S1100 units.
	ST90	Black stopper for 90mm sink units
	ST125	Black stopper for 125mm sink units
	FP90	Perforated top screen for 90mm sinks units
	FP125	Perforated top screen for 125mm units



a.

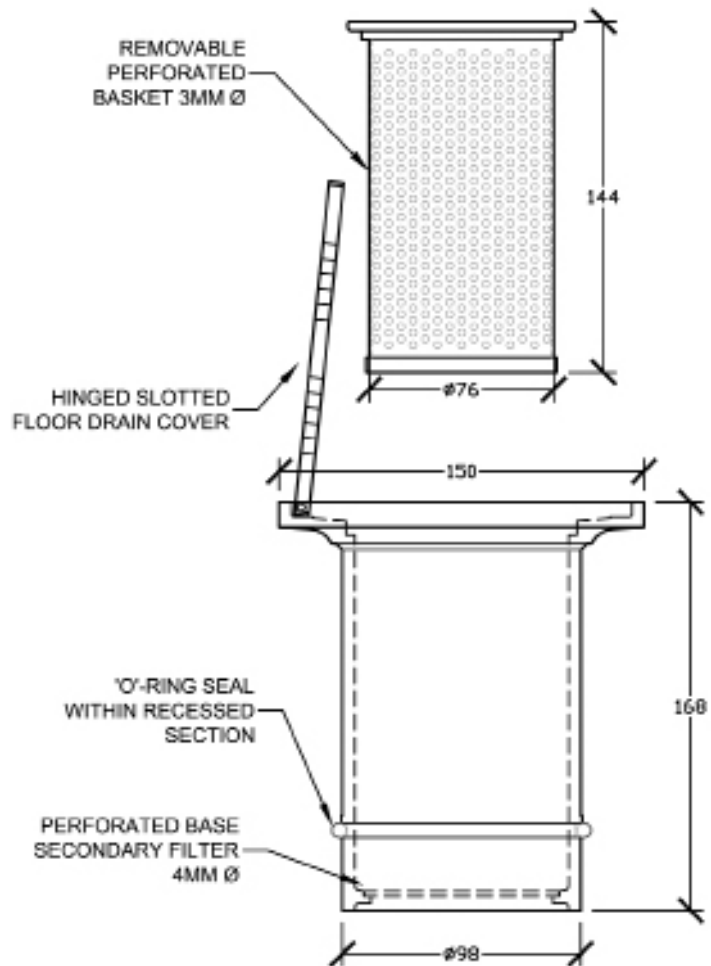

ITEM	STOCK CODE	DESCRIPTION
a.	F660	In Floor Drain Protector. Upper flange 150mm x 150mm. Drain Protector will fit 100mm drainage pipes. Easy to fit/remove stainless steel basket with 660cc capacity



**a.**



ITEM	STOCK CODE	DESCRIPTION
a.	F1600	Large In Floor Drain Protector. Upper flange 250mm x 250mm. Drain Protector will fit 150mm drainage pipes. Easy to fit/remove stainless steel basket with 1600cc capacity



a.

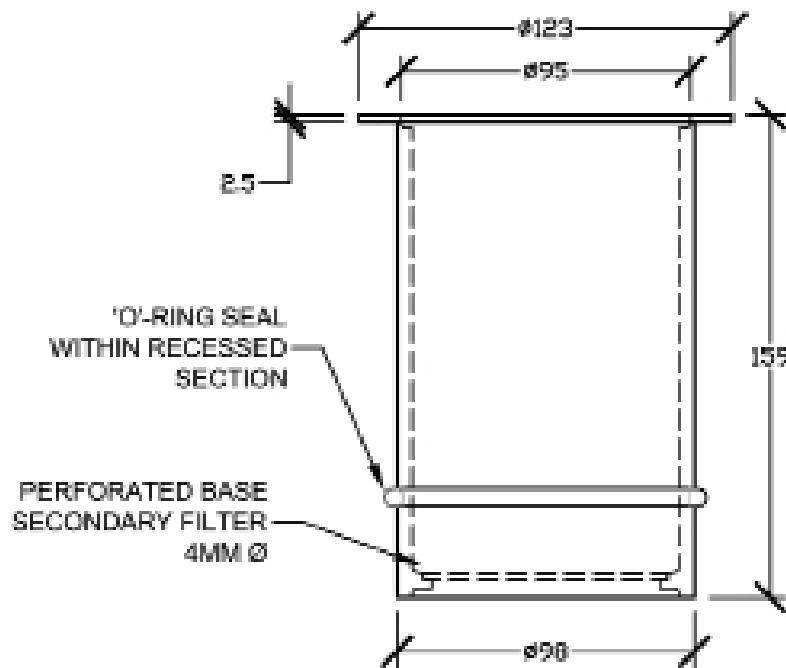

ITEM	STOCK CODE	DESCRIPTION
a.	FT660	In Floor Trough Drain Protector. Upper flange 123mm. Drain Protector will fit 100mm drainage pipes. Easy to fit/remove stainless steel basket with 660cc capacity



**a.**

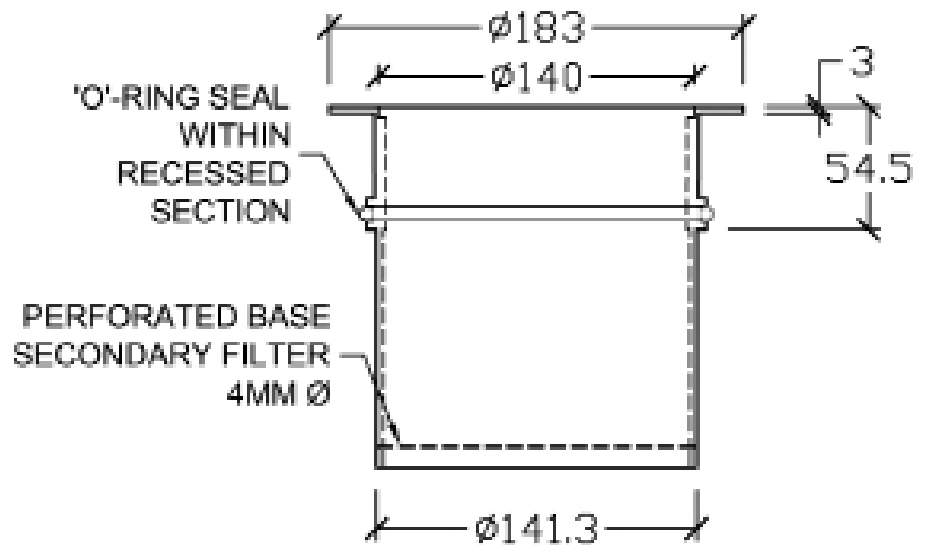

ITEM	STOCK CODE	DESCRIPTION
a.	<b>FT1600</b>	Large In Floor Trough Drain Protector. Upper flange 183mm. Drain Protector will fit 150mm drainage pipes. Easy to fit/remove stainless steel basket with 1600cc capacity
	<b>BF660</b>	Spare basket for FT660 & F660 units.
	<b>BF1600</b>	Spare basket for FT1600 & F1600 units.

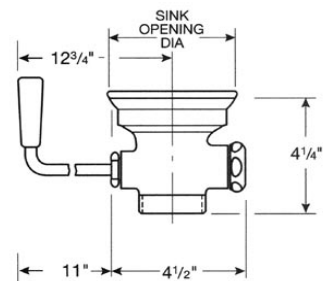
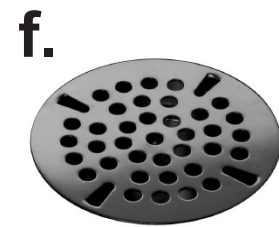
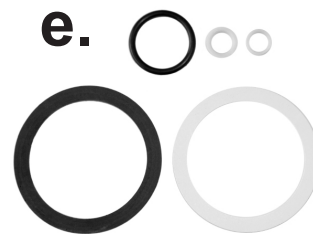

ITEM	STOCK CODE	DESCRIPTION
a.	50BWA	Plug and waste. Polypropylene and 304 stainless steel waste with stainless steel plug and scrap trap. Fits 89mm sink hole and attaches to standard 50mm pipe
b.	PW89/50	Plug and waste. Made in accordance with Australian Standard AS2887. Manufactured from glass reinforced polypropylene with a 304 stainless steel face. SAI approved to MP52-SPEC.005. Fits 89mm sink hole and attaches to standard 50mm pipe
c.	50PGR	50mm Plug & Waste. Manufactured from glass reinforced polypropylene with a stainless steel face
d.	40STD	40mm Plug & Waste. Manufactured from glass reinforced polypropylene with a stainless steel face
e.	72-RK	Replacement kit for WD20T includes flange rubber washer and paper gasket, body bushing, packing nut bushing and plug O-ring
f.	72-FS	Stainless steel flat strainer for WD-20T
g.	WD20T	Twist handle waste outlet. Stainless steel flat strainer

Overflow Tubes and Drains

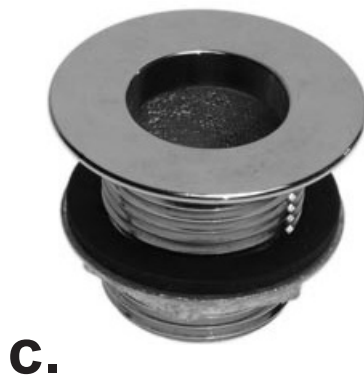
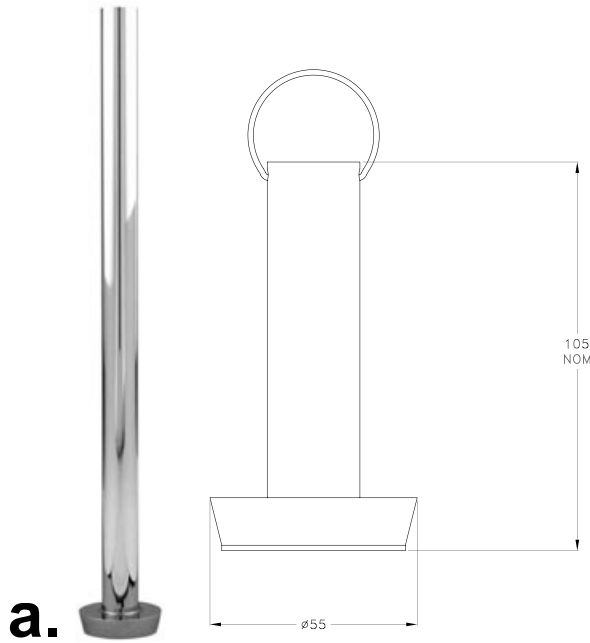

ITEM	STOCK CODE	DESCRIPTION	SIZE	LENGTH
a.	37333	Chrome plated standing overflow and 50mm plug <b>Note:</b> Minimum/nominal height 105mm or height made to order. Please advise when purchasing	50mm	105-300 mm
b.	K0460-2290	Overflow tube. Nickel plated brass with neoprene seat	1" NPS (25mm)	9" (229mm)
c.	E16-4011A	Sink drain to suit K0460-2290. Nickel plated brass with brass locknut and rubber washer	1" NPS (25mm)	1½" (38mm)
	E16-4031A	Sink drain to suit K0460-2290. Nickel plated brass with brass locknut and rubber washer	1" NPS (25mm)	4" (102mm)
d.	E13-0242	Overflow tube. Swedged stainless steel	1½" NPS (38mm)	10" (254mm)
e.	E18-1822	Sink drain to suit E13-0242. Stainless steel complete with brass locknut, rubber washer and brass tail piece	1½" NPS (38mm)	1½" (38mm)