

CDC2410CCST

Stainless Steel Cup Dispensing Unit Assembly Instructions

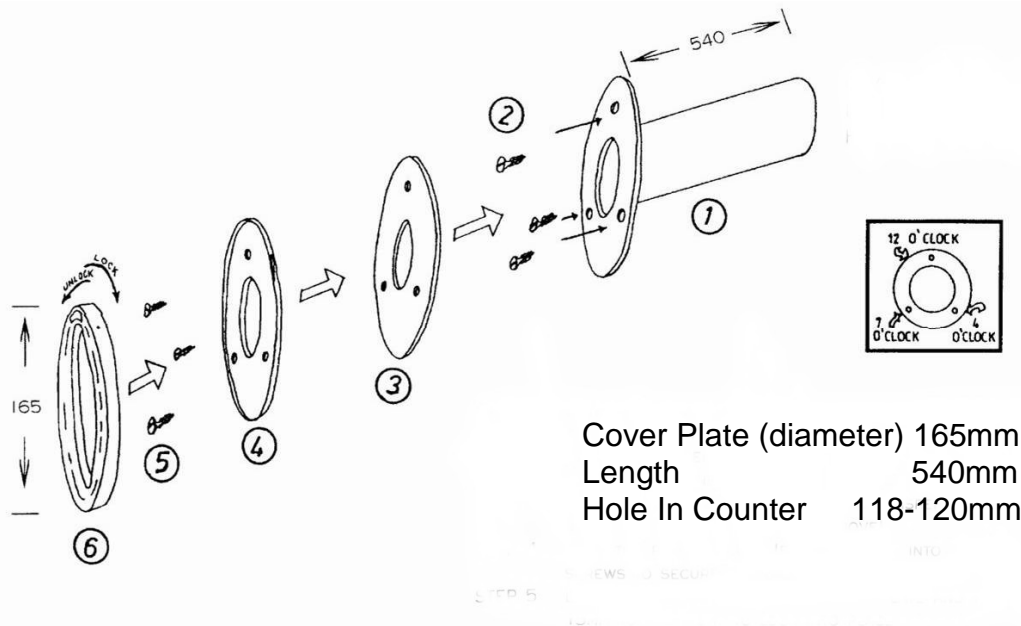

Step 1

Determine the final fitted position of the dispenser (part 1 above) and cut a hole 118mm to 120mm diameter maximum size.

Step 2

Place the dispenser in position as required and screw into position with one screw at 12 O'clock.

Step 3

Fit rubber gasket between the main dispenser (part 1 above) and the basket place (part 4 above).

Step 4

Push the plastic plugs (part 5 above) into the head of the screws to secure the gasket plate and gasket in place.

Step 5

Locate cover plate over dispenser plate and turn approximately 15mm to the right lock into place.





CDC2410CCST

Stainless Steel Cup Dispensing Unit

Use Guide Below To Select Correct Size Gasket

			Replacement Gasket Kits		
Approximate Cup Rim Diameter	Approximate Cup Size Range	Gasket Size	Part Numbers	Qty of Gaskets in Kit	
73mm (2-7/8")	79mm (3-1/8")	236ml (8oz) to 414ml (14oz)	Small XC2422S	3	
89mm (3-1/2")	98mm (3-7/8")	474ml (16oz) to 710ml (24oz)	Medium XC2422M	3	
106mm (4-3/16")	111mm (4-3/8")	947ml (32oz)	Large XC2422L	3	
114mm (4-1/2")	121mm (4-3/4")	947ml (32oz) to 1360ml (46oz)	XLarge XC2422XL	3	
One each of small, medium and large (xlarge not in kit)			XC2426	4	

